

# DIRECTION 231

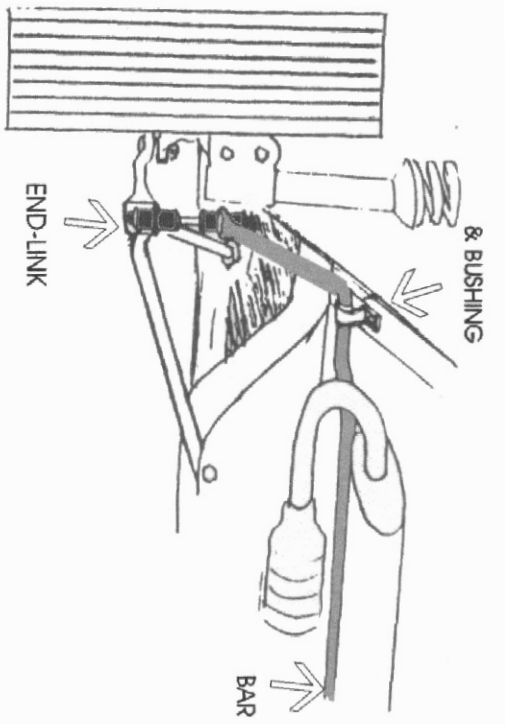

VIEW: LEFT REAR LOOKING FORWARD

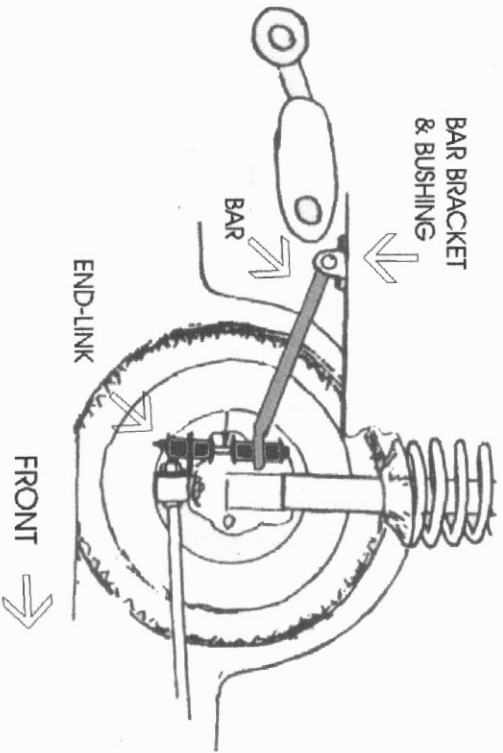

VIEW: LEFT SEEN FROM UNDER CAR

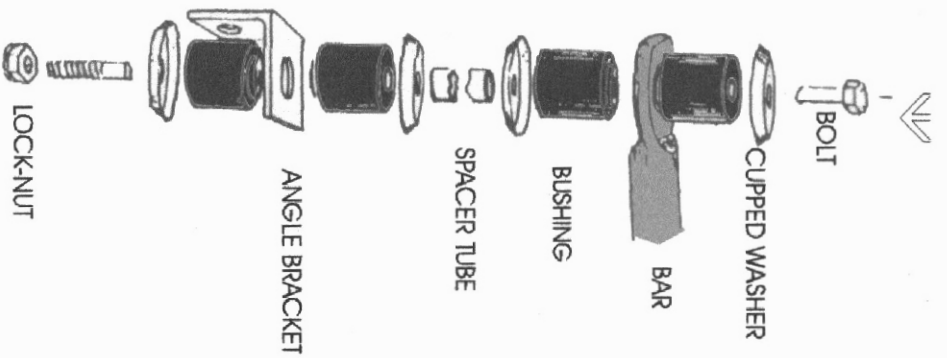

**Direction #231**

**MR-2 FULL KIT FOR VEHICLES WITH NO ORIGINAL BARS**

**Step #1.** Remove the bolts that are screwed into the frame bottom just forward of the muffler area. Place the bushings around the bar and after inserting bar forward of the muffler, use the bolts to secure the bar brackets to the existing hole in the frame. With bar arms forward the eyes should bend up (not down).

**Step #2.** Assemble the end-links as illustrated so as to connect the bar eye to the angle bracket eye in the longer side of the bracket.

**Step #3.** With the vehicle resting on its wheels and wheels locked, remove the nut upon the rear of the strut rod. Place the angle bracket on the rod and replace the nut securely. If there is excessive thread beyond the top of the nut, place the washer provided between the angle bracket and the cupped washer that rests against the bushing in the suspension arm.

**Step #4.** Bounce the rear of the car and make sure all parts clear throughout the suspension travel distance. Check all fastenings for suitable tightness. The nuts on the bottom of the end-links should only be snug because over-tightening them will result in premature failure of the end-link components. Road-test your MR-2 to familiarize yourself to its new handling. This kit should be used in conjunction with our front bar #786.

**NOTE:** As we cannot supervise your installation or driving, we cannot be responsible for more than the cost of the kit.

**HARDWARE**

<b>2</b>	<b>RH 046C</b>	<b>Brackets</b>
<b>2</b>	<b>UB 611B</b>	<b>Bushings</b>
<b>2</b>	<b>RH 028B</b>	<b>Angle Brackets</b>
<b>2</b>	<b>RH 015</b>	<b>End-Links</b>
<b>6</b>	<b>RH 111</b>	<b>Washers</b>
<b>4</b>	<b>RH 104</b>	<b>Washers</b>