



PART # 2341 chevy conversion van rear bar

IMPORTANT: READ BEFORE INSTALLATION!!

- STEP# 1** **INSTALL THE BUSHINGS AND BRACKETS ONTO THE MID-SECTION OF THE SWAY BAR. BE SURE TO APPLY AXLE GREASE TO THE INSIDE OF THE BUSHINGS.**
- STEP# 2** **THE BAR MOUNTS TO THE SHOCK BRACKETS LOCATED ON THE REAR AXLE. PLACE THE BAR UNDER THE AXLE WITH THE ARMS POINTING FORWARD AND THE MIDSECTION BRACKETS AGAINST THE SHOCK BRACKETS. MARK THE HOLES OF THE MIDSECTION BRACKETS ON THE SHOCK BRACKETS AND DRILL THE FOUR 7/16 MOUNTING HOLES. INSTALL THE SWAY BAR WITH THE SUPPLIED FASTENERS ON TORQUE TO APPROX. 20 FT LBS.**
- STEP# 3** **INSTALL THE ENDLINKS AND THE FRAME BRACKETS ON THE SWAY BAR. DO NOT OVER TIGHTEN THE ENDLINKS: THEY ONLY NEED TO BE SNUG. MARK THE LOCATION OF THE FRAME BRACKET HOLES ON THE FRAME AND DRILL FOUR 7/16 HOLES. INSTALL THE U-BOLTS AND THE BRACKETS. TORQUE TO APPROX. 15 FT LBS.**
- STEP# 4** **AFTER THE INSTALLATION IS COMPLETE; BOUNCE THE CAR TO CHECK THE CLEARANCE OF ALL PARTS THROUGH OUT THE SUSPENSION TRAVEL DISTANCE.**
- STEP# 5** **ROAD TEST YOUR CAR TO FAMILIARIZE YOURSELF WITH ITS NEW HANDLING. AS WE CANNOT SUPERVISE YOUR INSTALLATION OR YOUR DRIVING, WE CANNOT BE HELD RESPONSIBLE FOR MORE THAN THE COST OF THE KIT. FOR BEST BALANCE AND CONTROL, THIS BAR SHOULD BE USED IN CONJUNCTION WITH OUR FRONT KIT.**

HARDWARE LIST:

- 2 – 613D BUSHINGS**
- 2 – 046 BRACKETS**
- 2 – 044 BRACKETS**
- 2 – 402 U-BOLTS**
- 4 – 214 BOLTS**
- 8 – 104 WASHERS**
- 8 – 304 NUTS**

Direction 2341

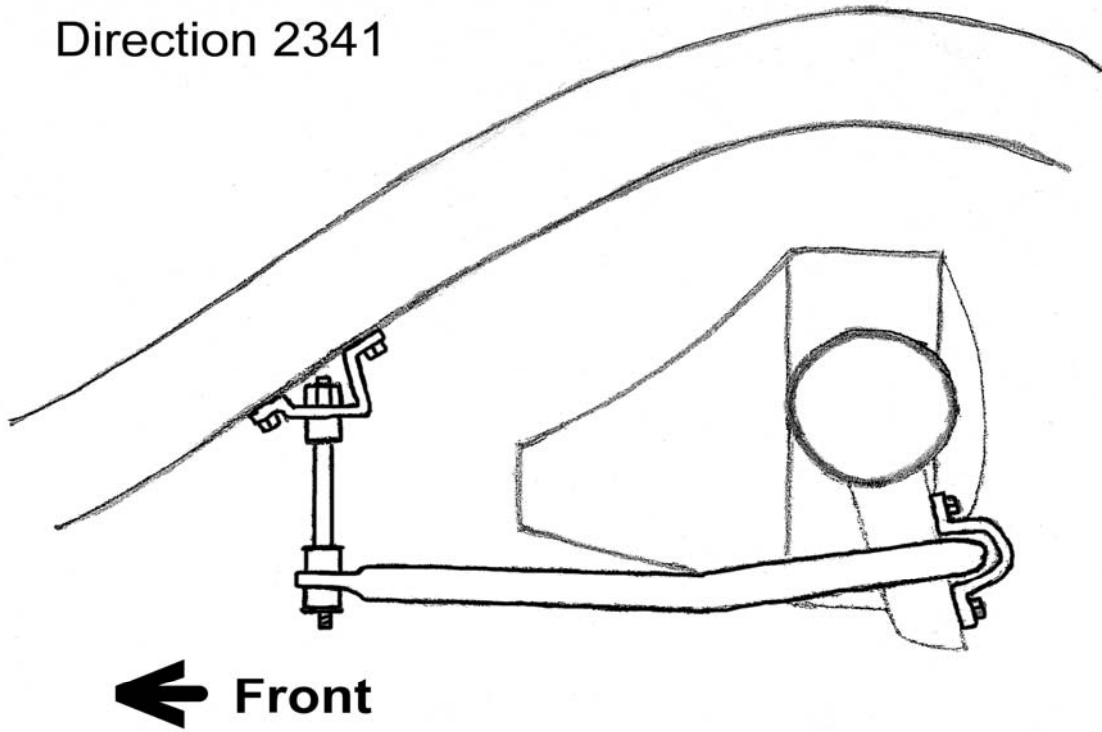

Installing a 402 U-Bolt Detail

