

DIRECTION 235

U-BOLT DETAIL

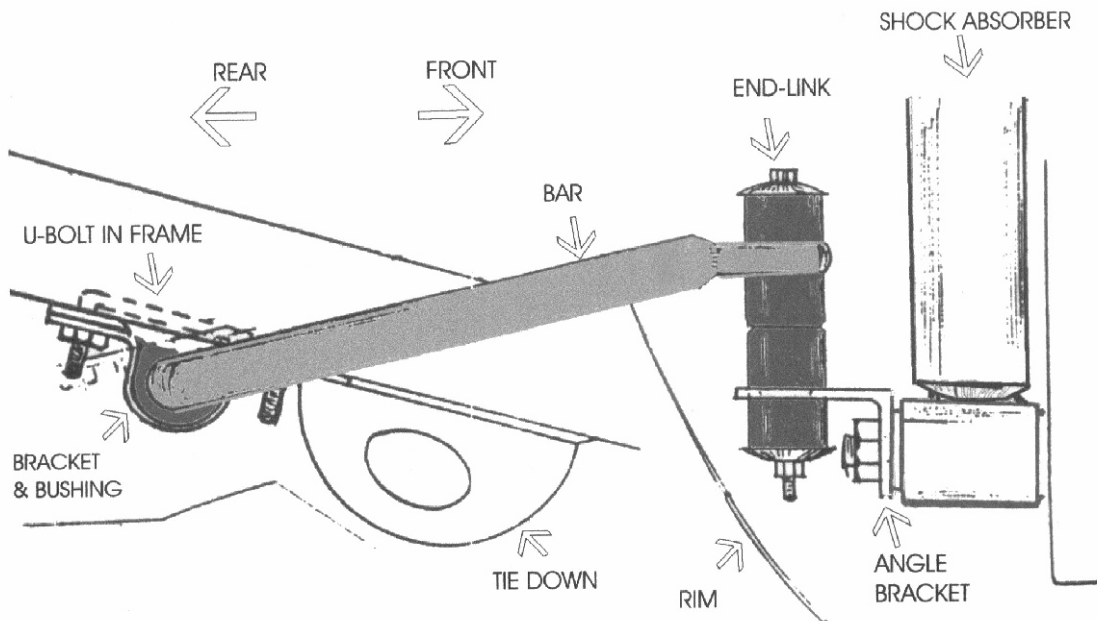
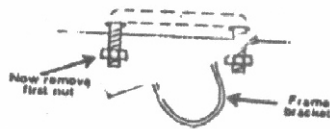
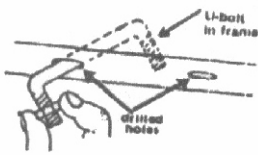

Direction #235

- Step #1.** Remove the retainer nut on the rear of the shock absorber lower end. Place the smaller of the two holes in the supplied angle bracket on the stud in place of shock washer and replace the nut. Turn the angle so the large hole is above and to the rear of the shock retainer nut before tightening it.
- Step #2.** Tie the mid-section of bar to the frame with a piece of string so the forged ends point horizontally over the angle bracket when the arms of the bar point forward and up as illustrated. The bar mid-section will cross the frames to the rear of the rear hold down eyes.
- Step #3.** Assemble the end-links as shown, with the cupped washers at the top and bottom, and bar eye held above the angle bracket. Tighten the nuts until the center bolt keeps the end-link assembly snug but not so tight as to distort the bushing.
- Step #4.** Place the bushings on the bar mid-section under the frame centers with the flat sides up against frame. Place the bar brackets around the bushings and mark through the holes. Drill the frame bottom with a 3/8" drill bit. Be sure that the end-links are vertical when the hole locations are marked.
- Step #5.** Place a nut on the end-link of the U-bolt and insert the other end into the frame. Maneuver it until it reappears from the other hole, and pass it through a hole in the bracket, and start another nut on it. Remove the first nut and place the free end of bracket over the U-bolt end and replace the nut. Tighten the nuts on the U-bolts to secure the bar.
- Step #6.** Check all fastenings for suitable tightness. Road test the vehicle to familiarize yourself its new handling. As we cannot supervise your installation or driving, we cannot be held responsible for more than the cost of the kit.

NOTE: For best balance and control, this kit should be used in conjunction with our front kit.

HARDWARE

4	RH 304 Lock-Nuts
2	RH 013 End-Links
2	RH 510 Bushings
2	RH 040 Brackets
2	RH 023 Angles
2	RH 402 U-Bolts