

DIRECTION 239

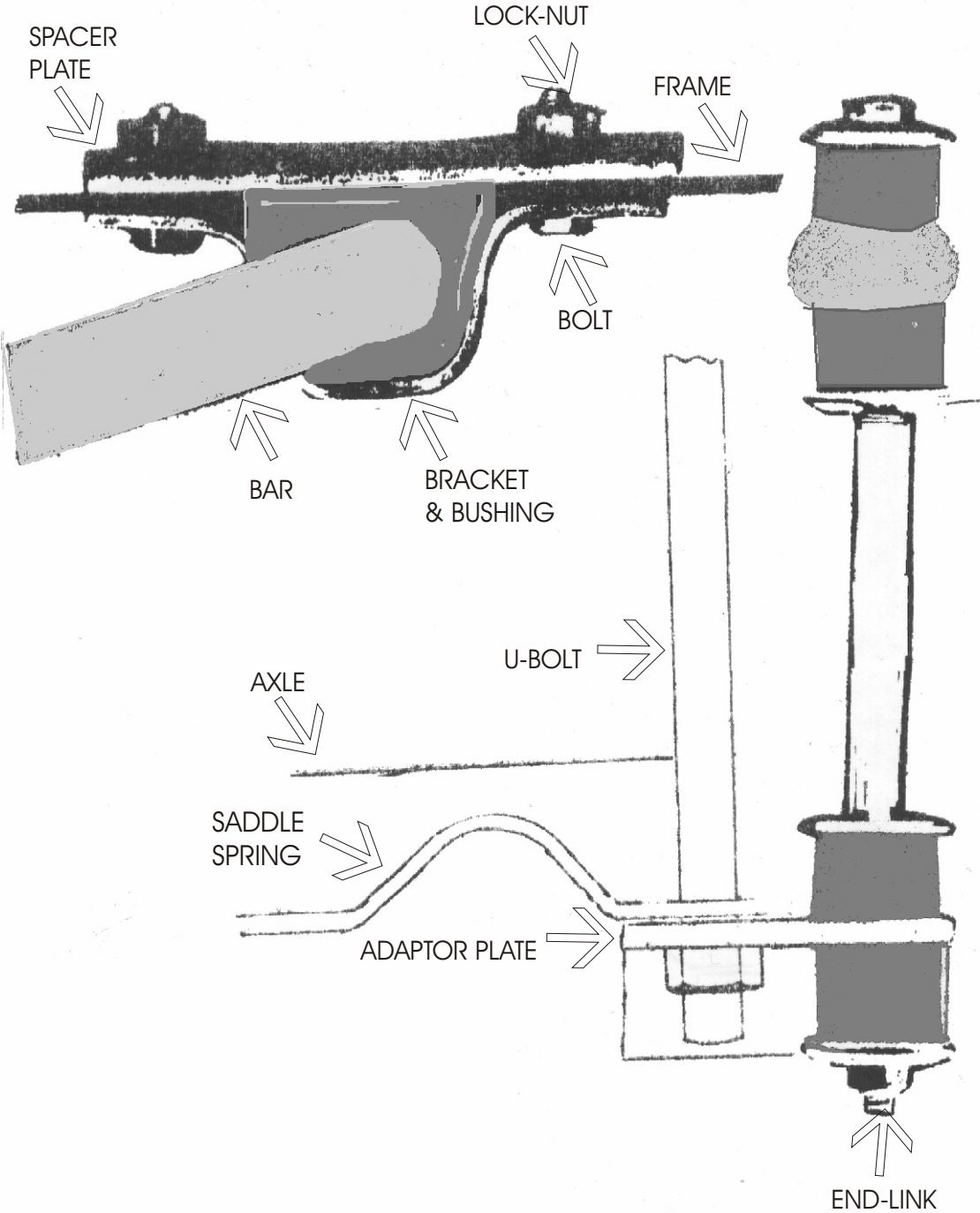

VIEW: LEFT SIDE LOOKING AFT

Direction 239

- Step #1. Remove rear inboard nut from under the spring saddle. Place adaptor angle on the U-bolt end and replace nut. Position so that the hole for the end-link lies slightly forward of the other end so as to be clear of the axle and is inboard of the saddle.
- Step #2. Assemble end-links so as to connect bar eye and hole in the adaptor plate. Do not tighten nut on the bottom of the end-link assembly kit. The mid-section of the bar must be placed to the rear of the axle with arms sloping forward and down to end-links.
- Step #3. Place rubber bushings on the bar near the shoulders and raise bar to the frame. Adjust so that the bar ends are 1" from the axle and the end-links are near vertical (within 10 degrees is okay). Mark the frame bottom for drilling.
- Step #4. Using the bracket as a template, drill two holes (3/8" diameter) in each frame. Using the bolts and lock-nuts supplied, bolt the bracket to the frame bottom with the plate inside the frame.
- Step #5. Tighten nut on bottom of end-link until assembly is snug. Do not over tighten. Check for clearance throughout the suspension travel distance.
- Step #6. Road test the vehicle to familiarize yourself to its new handling. As we can not supervise your installation or your driving, we can't be held responsible for more than the cost of the kit.

HARDWARE

2	RH 017 End-Links
2	RH 509 Bushings
2	RH 040 Brackets
2	RH 031 Plates
2	RH 035 Angles
4	RH 214 Bolts
4	RH 304 Lock-Nuts
4	RH 104 Washers