

DIRECTION 304

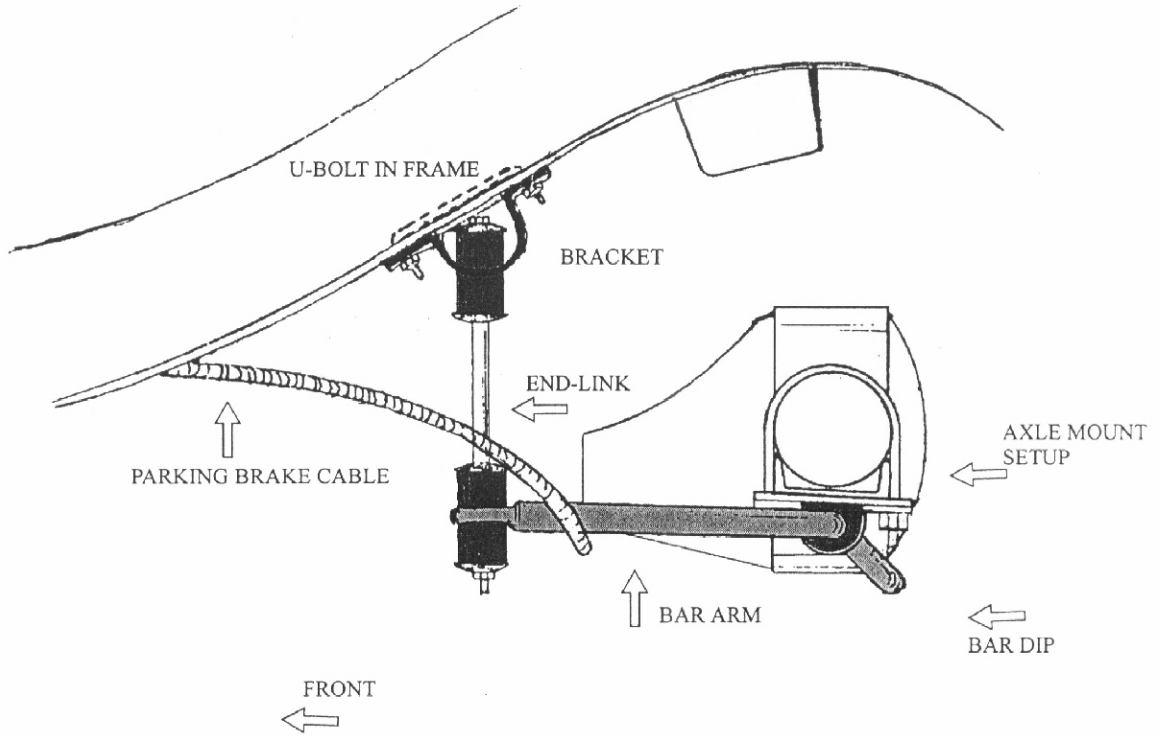

HOW TO INSTALL A 402 U-BOLT

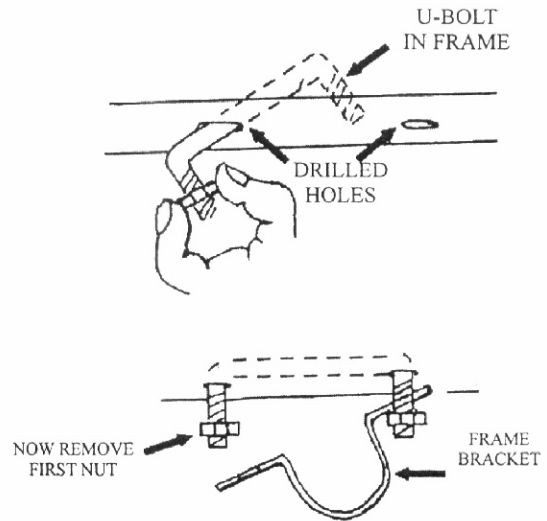
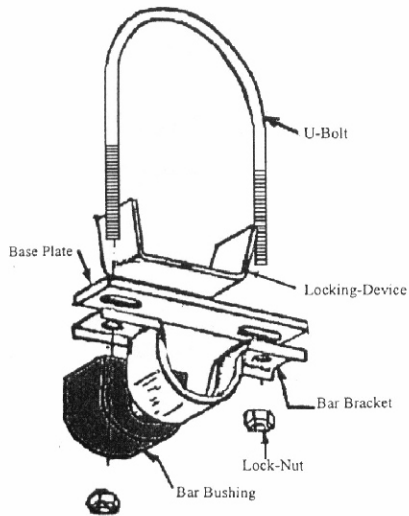

DIRECTIONS 304

- Step #1.** Hang U-bolt around axle. Raise up slotted plates under the U-bolt so as to engage the U-bolt legs. Follow with the bar bracket that should already be around the bar. Start the nuts place the D-shaped bushings on the bar near the bends flat side up. Next slide the loosely assembled U-bolt and bracket assembly down the axle so that the bracket is around the rubber bushing. Insert the locking device from one side, legs towards axle, center on slotted plate.
- Step #2.** Assemble end-link as illustrated. Pass the end-link center bolt through one cupped washer; through a rubber bushing; through the frame bracket (from inside it); through another bushing; another washer; the tube spacer; another washer; another bushing; the bar eye; another bushing, the last cupped washer; and secure with a lock nut. Be sure that washers have their cupped or hollow side towards the rubber bushing, and that the rubber bushing have the end with the stepped surface towards the bracket or bar eye. Tighten the lock-nut so the assembly is securely snug but not so tight that the bushings bulge to a noticeable extent.
- Step #3.** The bar should be positioned so that the mid-section runs under the rear axle with the arms facing forward and the dip down and to the rear.
- Step #4.** Position bar so that the forges are horizontal and the axle clamp assembly holding the bar mid-section below the axle. With the car resting naturally on its springs on level ground, the frame brackets should position themselves so as to align with the frame bottom. Adjust the bar position relative to the axle if needed.
- Step #5.** Mark through the frame bracket holes. Drill one hole with a 3/8" drill bit. Use the square U-bolt to get the exact spacing for the second hole and drill it.
- Step #6.** Place a lock-nut on one leg of the square U-bolt. Insert the other end into one drilled hole. Maneuver it until it reappears through the other drilled hole. Place one end of the frame bracket over the leg and start another lock-nut on it. Remove the first nut; position free end of bracket over the U-bolt leg and replace the nut.
- Step # 7.** Have someone bounce the rear of the car so you can check that all parts of the bar and hardware clear throughout the suspension travel distance. If rubber stops are visible, measure the maximum travel distance so you can better estimate clearances. If all clear, tighten nuts on the frame and axle.
- Step #8.** Road test the car to accustom yourself to its new handling. As we cannot supervise your installation (or your driving) we cannot be held responsible for more than the cost of the kit. NOTE: For best balance and control this kit should be used in conjunction with our front bar.

HARDWARE

2 RH 014 End-links	2 RH 510 Bushings
2 RH 046 Brackets	2 RH 044 Brackets
2 RH 055 Channel Brackets	2 RH 031 Plates
2 RH 407 U-Bolts	2 RH 402 U-Bolts
8 RH 304 Lock-Nuts	4 RH 104 Washers

DIRECTIONS 303

This bar is designed to replace your present anti-sway bar with no modification necessary. As you can see, the bar is similar, the only change on some bars is a modification of the contours made necessary by the increase in bar diameter. This bar uses the original hardware now on the car (bushings, clamps, end-links). It may be necessary to either cut one side of the rubber sleeves that hold the original bar or to bore them out (with a rat tail file) if the bar you ordered is a great deal larger in diameter than the original. This will in no way harm the operation. If the existing end links and/ or bushings are badly worn, new sets can be obtained from your automobile dealer. On some cars (example: Camaro, Firebird), installation is greatly simplified by removing one wheel and jacking the frame of the car up so as to allow the wheel assemblies to hang.

After installation, check the movement of the car on the suspension and make sure that all parts of the frame, engine, A-arms, steering, brake lines, etc. cannot come in contact with the suspension travel. After checking the above, and that all fastenings are of suitable tightness, road test the vehicle and accustom yourself to the vehicle's new handling characteristics. It will handle flatter and steadier, but be ready for an increase in under steer unless you have already installed our anti-sway bar on the rear. The addition of a rear kit, of course, would give your car even flatter cornering and near neutral steering characteristics.

As we cannot supervise your installation or driving, we cannot be held responsible for more than the cost of the kit.

HARDWARE

2	UB 612B	Bushings
2	RH 046C	Brackets
2	RH 015	End-links
4	RH 104	Washers