

DIRECTION 326

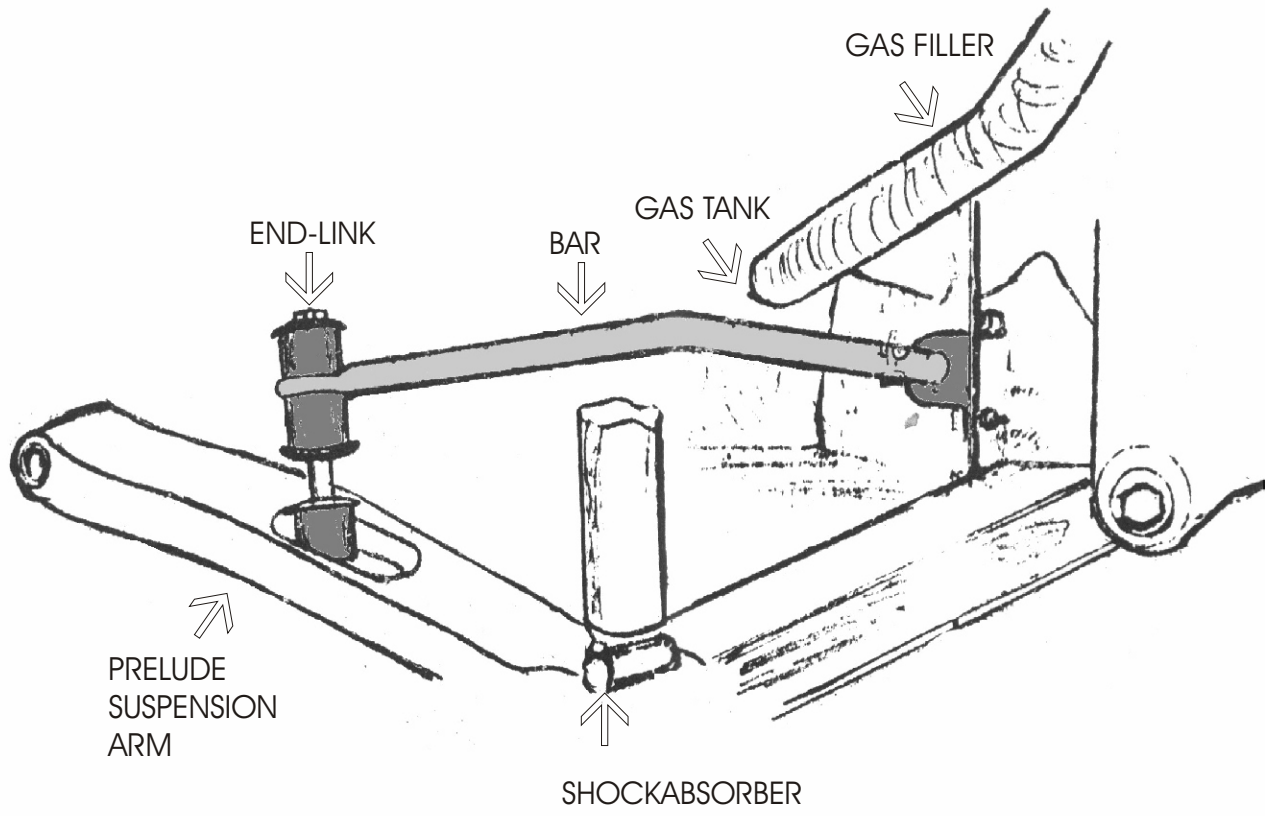

DIRECTIONS 326

- STEP #1.** **Remove the rear bar.**
- STEP #2.** **Insert the bar between the transverse rear suspension support structure and the gas tank. The small bolts holding the tabs on the rear of the gas tank may have to be removed and the rear of the tank temporarily lowered slightly. Arms of the bar should be forward.**
- STEP #3.** **Pass one of the supplied 5/16" bolts through the center hole of the backing plate which has the 3/8" center hole. Pass another through the outer slot of the plate in the opposite direction. Pass the center bolt through the lower existing hole and secure with a lock-nut and tighten to 15 lbs/ft.**
- STEP #4.** **Place the spacer plate, bar bracket and bushing (holding the bar) against the backing plate and secure with another bolt and nut through the upper existing hole. Using another lock-nut secure the bottom of the bracket to the lower bolt previously put through the backing plate. Secure all nuts to 15 lbs/ft.**
- STEP #5.** **Assemble the end-link as illustrated. The tube spacer goes between the center washers.**
- STEP #6.** **Check all fastenings for suitable tightness. Bounce the rear of the car so as to check that all parts clear throughout the suspension travel distance. Road test the car so as to accustom yourself to your car's new handling. As we cannot supervise your installation or driving, we cannot be responsible for more than the cost of the kit**
- NOTE:** **This kit should be used in conjunction with our kit #177 front bar for best control and cornering balance.**

HARDWARE

- | | |
|----------|------------------------------|
| 2 | UB 611B Bushings |
| 2 | RH 015 End-Links |
| 2 | RH 042B Half Brackets |