

# DIRECTION 422

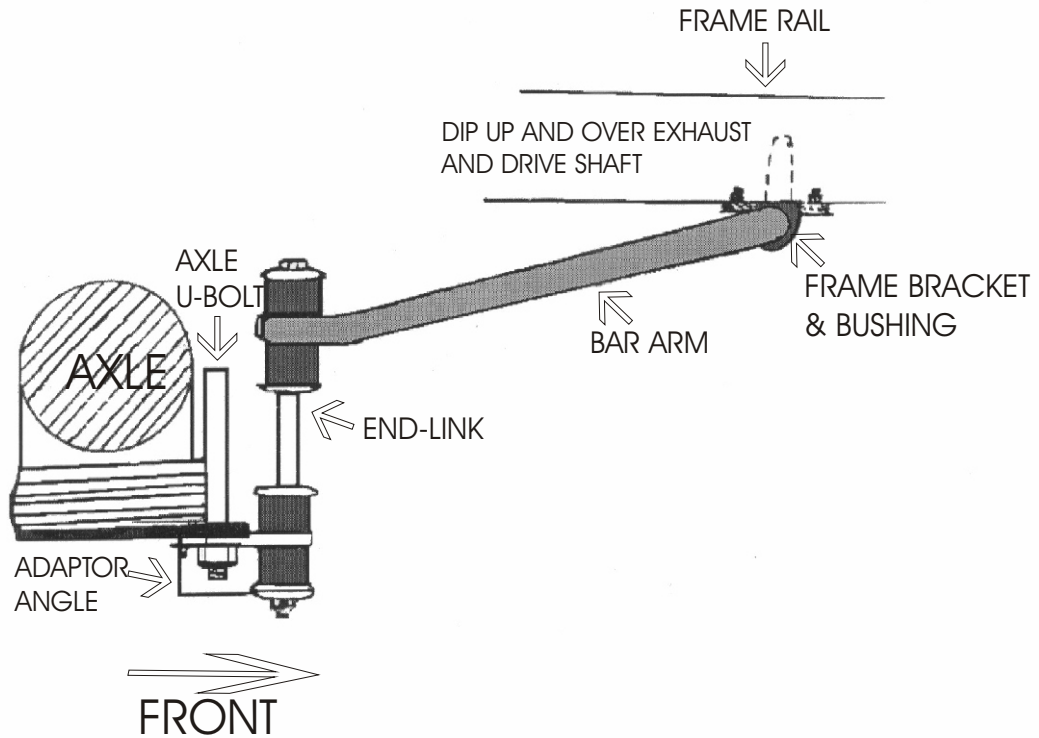

NOTE: THE P-30 CHASSIS THE LEAF SPRINGS ARE MOUNTED TO THE OUTSIDE OF THE FRAME RAILS. FOR PROPER ILLUSTRATION OF INSTALLATION THE LEAF SPRINGS HAVE BEEN OMITTED FROM THE ILLUSTRATION.

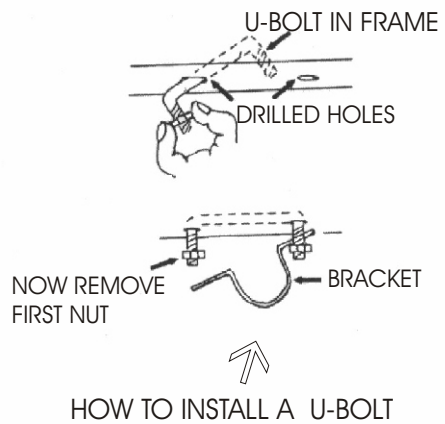

## **DIRECTIONS 422     P-30 CHASSIS**

- STEP #1.**            Remove rearward inboard nut from under the spring saddle. Place adaptor angle on the u-bolt end and replace nut. Position so that the hole for the end-link lies slightly forward of the other end so as to be clear of the axle, and is inboard of the saddle.
- STEP #2.**            Assemble end-links so as to connect bar eye and hole in the adaptor plate. Do not tighten nut on the bottom of the end-link assembly yet. The mid-section of the bar must be placed to rear of axle with arms sloping forward and down to end-links.
- STEP #3.**            Place rubber bushing on the bar near the shoulders and raise bar to the frame. Adjust so that the bar ends are 1" from the axle and the end-links are near vertical (within 10 degrees should be okay). Mark the frame bottom for drilling.
- STEP #4.**            Using the bracket as a template, drill two holes 3/8" diameter in each frame. Using the bolts and lock-nut supplied, bolt the bracket to the frame bottom with the plate inside the frame.
- STEP #5.**            Tighten nut on bottom of end-link until assembly is snug. Do not over tighten. Check for clearance throughout the suspension travel distance. Start engine.
- STEP #6.**            Test drive your truck and accustom yourself to its new handling. As we cannot supervise your installation (or driving), we cannot be responsible for more than the cost of the kit. Note: On the P-30 chassis the leaf springs are mounted to the outside of the frame rails. For proper illustration of installation the leaf springs have been omitted from the illustration.

### **HARDWARE**

<b>4 RH 509 Bushings</b>	<b>2 RH 043 Brackets</b>
<b>2 RH 040 Brackets</b>	<b>2 RH 041 Brackets</b>
<b>2 RH 034 Plates</b>	<b>2 RH 034B Plates</b>
<b>2 RH 402 U-Bolts</b>	<b>2 RH 065 Tubes</b>
<b>2 RH 208 Bolts</b>	<b>4 RH 218 Bolts</b>
<b>4 RH 104 Washers</b>	<b>4 RH 307 Lock-Nuts</b>
<b>6 RH 304 Lock-Nuts</b>	<b>4 RH 104 Washers</b>
<b>4 RH 500 Bushings</b>	