

DIRECTION 433

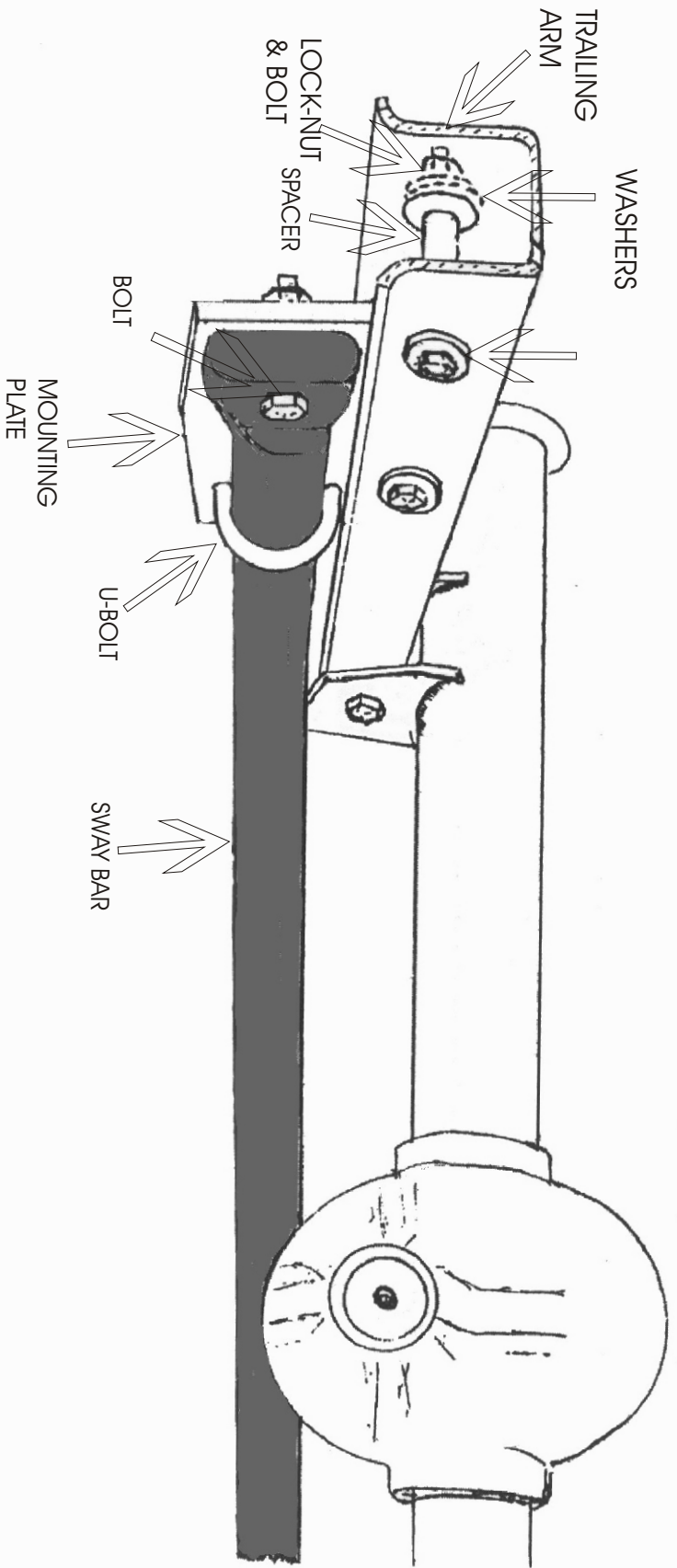

DIRECTIONS 460

- STEP #1.** Remove original bar if your car has one.
- STEP #2.** Bolt the mounting plates to the bar first using the bolts and U-bolts provided.
- STEP #3.** Position the bar under the car arms forward with the upper holes of the plates aligning with the trailing arms. Rest the ends of the bar on blocks to keep it in the approximate correct location. Raise the other end into position so the mounting plate is inside the trailing strut and against the inboard side. Mark the strut for drilling using the holes in the plate (GM supplied 4 different holes in the strut plus many of this type struts with no holes). If one or more align with the plate hole, they may be used. Drill the holes with a 3/8" drill bit.
- STEP #4.** Pass the long bolts from the inboard side through a washer, the existing hole in the trailing strut, through the hole in the mounting plates, through the spacer, and the outboard existing hole. Secure with another washer and lock-nut. Repeat on the other side.
- STEP #5.** Tighten U-bolts nuts to 20 ft lbs. Tighten the other lock-nuts to 30 ft lbs.
- STEP #6.** Road test vehicle to familiarize yourself with it's new handling. As we cannot supervise your installation, or your driving, we cannot be held responsible for more than the cost of the kit.

HARDWARE:

2 RH 611	Mounting Plates
2 RH 400	U-Bolts
2 RH 213	Bolts
4 RH 207	Bolts
8 RH 104	Washers
4 RH 067B	Tube Spacers
10 RH 304	Lock-Nuts