

DIRECTION 468

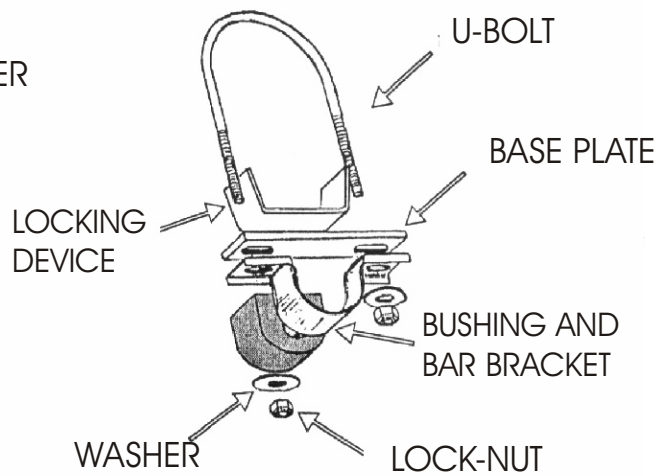
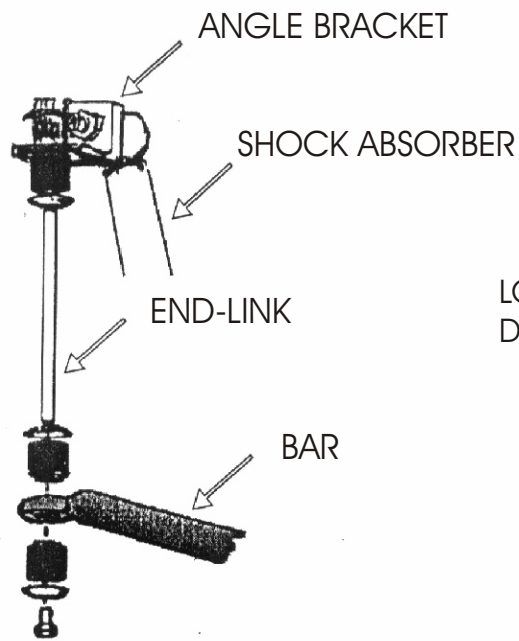
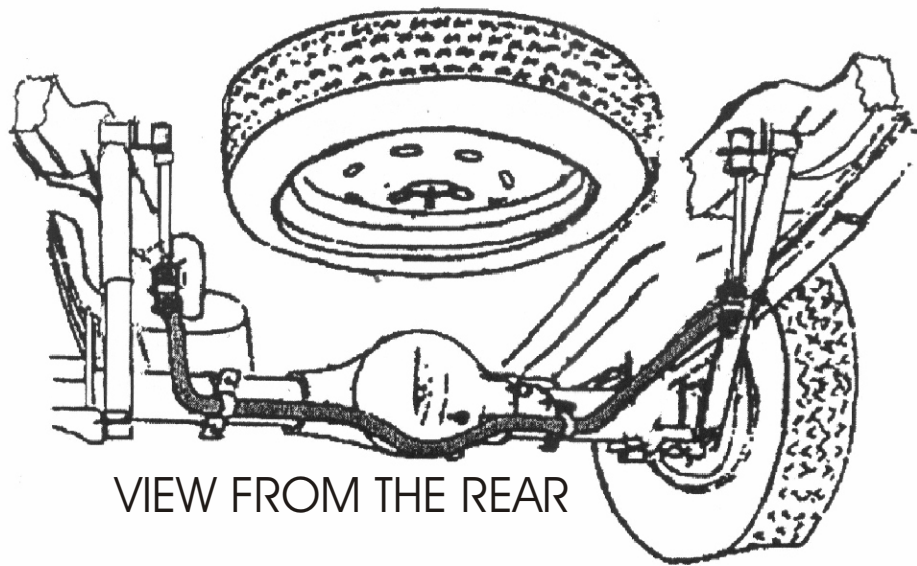

DIRECTIONS 468 4 WD REAR

NOTE: On trucks that have been lifted with heavier springs, the end-link assemblies should be lengthened by the same amount as the lift.

- STEP #1.** Pass the U-Bolt around the axle, making sure that they are between the brake line and the axle housing. The U-Bolts should be as far apart as possible for maximum bar effectiveness. **FOR YOUR SAFETY! ALWAYS USE CAUTION WHEN WORKING UNDER AN ELEVATED TRUCK.** You may need to remove the steel cover from the brake line in order to clear the U-bolt. Remove the nut that holds the top of the shock, place the angle bracket in position and replace the nut securely.
- STEP #2.** Install the D-bushings on the sway-bar center section. Install the locking device and base plates on the U-Bolt legs. Install the bar, arms pointing to the rear. Install D-bushing brackets, flat washers and lock-nuts onto the U-Bolt legs. Tighten the lock-nuts leaving just enough slack for minor position adjustments of the bar on the axle.
- STEP #3.** Assemble the end-links on the bar ends and to the existing 5/8" holes in the angle brackets that is behind the rear axle. Tighten the end-link bolts until the bushings just snug.
- STEP #4.** Make position adjustments to the bar so that the end-links are as close to straight up and down as possible and that the ends of the bar are square to the end-link bolts. If the truck was raised up and the rear axle allowed to hang, it should be lowered at this time so that adjustment will correct.
- STEP #5.** Tighten all fasteners to 20 lb/ft. The locking devices should spread and lock onto the axle housing. Re-check the end-link bolts for the proper tightness.
- STEP #6.** Road test your truck to familiarize yourself with its new handling. As we cannot supervise your installation or driving we cannot be held responsible for the cost of more than the kit. For best balance and control a rear bar should not be installed unless the truck is equipped with a front bar. Contact your dealer for information on our front bars.

HARDWARE

2 RH 407 U-bolts	2 RH 01 End-Links
2 RH 508 Bushings	4 RH 104 Washers
2RH 046 Bracket	2 RH 031 Plates
2RH 055 Locking Devices	2 RH 020 Angle Brackets
4RH 304 Lock-Nuts	