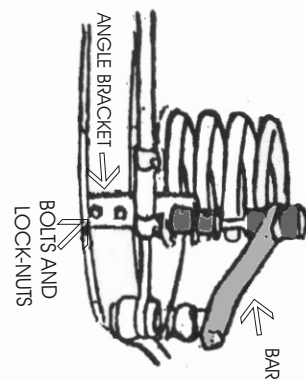
**DIRECTIONS 710S**

- STEP #1.** Remove the existing bolts attaching the forward end of the front-end braces.
- STEP #2.** Using the longer screws supplied, pass them through the washers, the bar brackets (around the bar) and the base plate and start into the original holes in the front end braces. Secure the assembly to 25 ft lbs. torque, after checking that the bar arms are resting on top of the steering rods with the tip down.
- STEP #3.** Position the angle bracket on the front of the lower control arms as illustrated. Locate under the bar eye, mark the control arm through the two small holes. Drill with a 3/8" drill bit (make sure the bracket is positioned so one hole is above and one hole is below the reinforcement web inside the control arm). Secure the angle brackets as per illustration with short 3/8" bolts and lock-nuts.
- STEP #4.** Assemble the end-links as per illustration, to connect the angle bracket to the bar eye. Do not over tighten the end-link nut. It should just be snug.
- STEP #5.** Check all fastenings for suitable tightness. Road test your vehicle to familiarize yourself with its new handling. As we cannot supervise your installation or your driving, we cannot be held responsible for more than the cost of the kit. For best balance and control this kit should be used in conjunction with our rear bar #984.

**HARDWARE**

2 RH 511 Bushings	2 UB 614 Urethane Bushings
2 RH 014 End-links	8 UB 609 Urethane Bushings
2 RH 902 Springs	2 RH 046 Brackets
4 RH 104 Washers	2 RH 031 Brackets
4 RH 226 Bolts	4 RH 214 Bolts
8 RH 304 Nuts	2 RH 026 Angle Brackets
1 RH 904 Grease	1 BK 100 Handling Book