

DIRECTION 921

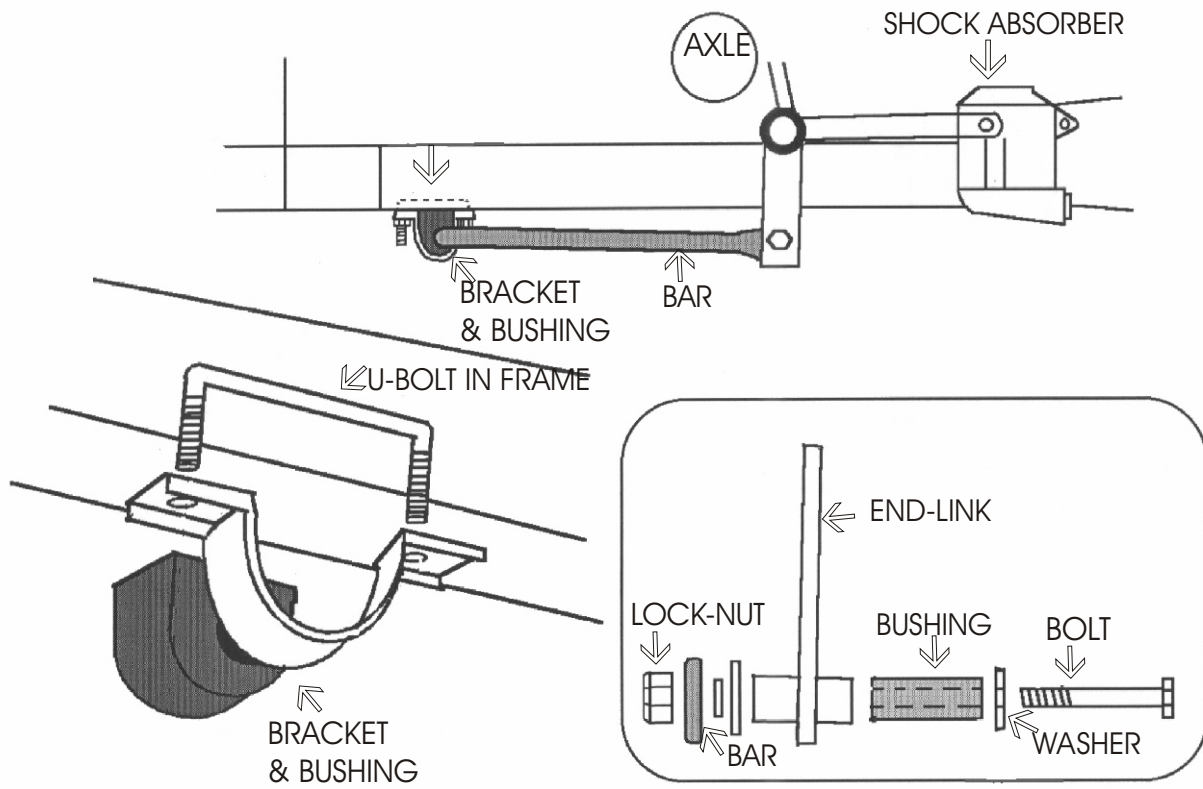

HOW TO INSTALL
A 402 U-BOLT

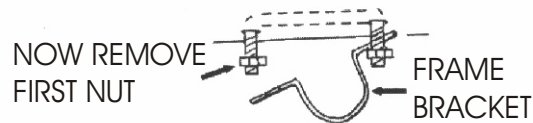
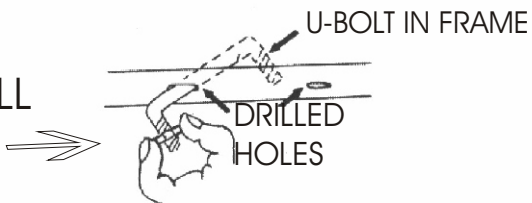

Direction #921

- Step #1.** Place the "D" shaped bushing on the bar, flat side up. Position bar on the bottom of frame to rear car wheels with arms pointing forward so ends of bar fall directly below "elbow" of the shock absorber (at end of arm leading back from shock absorber). Position frame bracket around the bushing and mark frame through holes. Drill with a 3/8" bit.
- Step #2.** Place a lock-nut on the end of the U-bolt: pass other leg through one hole in the bar bracket; then pass it through one of the drilled holes in to the frame. Maneuver until it drops out of the other hole. With the bracket holding the bar and bushing, secure free leg of U-bolt with another lock-nut. Tighten to 10 ft/lbs.
- Step #3.** Assemble end links as shown; insert small neoprene insert (work it in with a screw driver) in to end-link. Slide flat washer on to the cap screw and then slide the screw through the end link insert, then slide on another washer, the jam-nut (not very tight, just enough to keep the neoprene snug), then the bar and follow with the lock-nut.
- Step #4.** Remove the nut from the end of the shock absorber arm, slip on the upper hole of the end link and replace nut. (In some installations the stud may be replaced by a long bolt).
- Step #5.** Check all fastenings for suitable tightness and road test the vehicle. Take time to get accustomed to the new handling. As we cannot supervise your installation or driving, we cannot be responsible for more than the cost of the kit.

HARDWARE:

2 RH 011 End-links	2 RH 510 Bushings
2 RH 504 Bushings	2 RH 040 Brackets
2 RH 402 U-bolts	2 RH 206 Bolts
4 RH 104 Washers	6 RH 304 Lock-Nuts